

250 Series Receptacle and Tab Combination Termin.

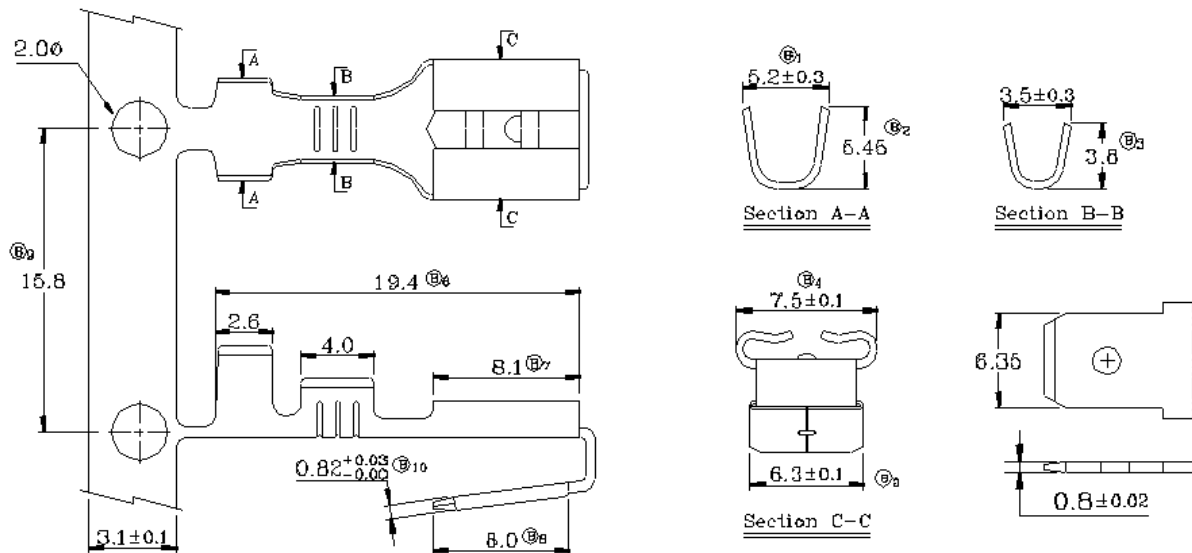

Specifications & Ordering Information:

Part No	Thickness	Material	Wire Range	Insulation O.D.	Finish	Qty/reel
2607BS-0	0.4	Brass	AWG #14~18	3.5-2.8 mm	None	1,500 PCS
2607BS-2	0.4	Brass	AWG #14~18	3.5-2.8 mm	Tin-Plated	1,500 PCS
2607BS-6	0.4	Brass	AWG #14~18	3.5-2.8 mm	Pre. Tin-Plated	1,500 PCS

REV	DATE	REV	DATE
A	5.29.1999		
B	10.14.2000		

HO CHIEN
www.hochien.com

UNIT : mm	APPROVAL	CHECKED	DRAWING	PRODUCT
TOLERANCE : .000 : ± 0.08 .00 : ± 0.13 .0 : ± 0.25				2607